



**WRH Industries, Ltd.**  
Innovators in Plastics since 1958

*Our Strength is Your Security.*

957 Airport Road, Fall River, MA 02720 USA  
1-800-FDA-TRAY (1-800-332-8729)  
1-508-674-2444 | [solutions@wrh.net](mailto:solutions@wrh.net)

**For complete product information, visit [www.wrh.net](http://www.wrh.net)**

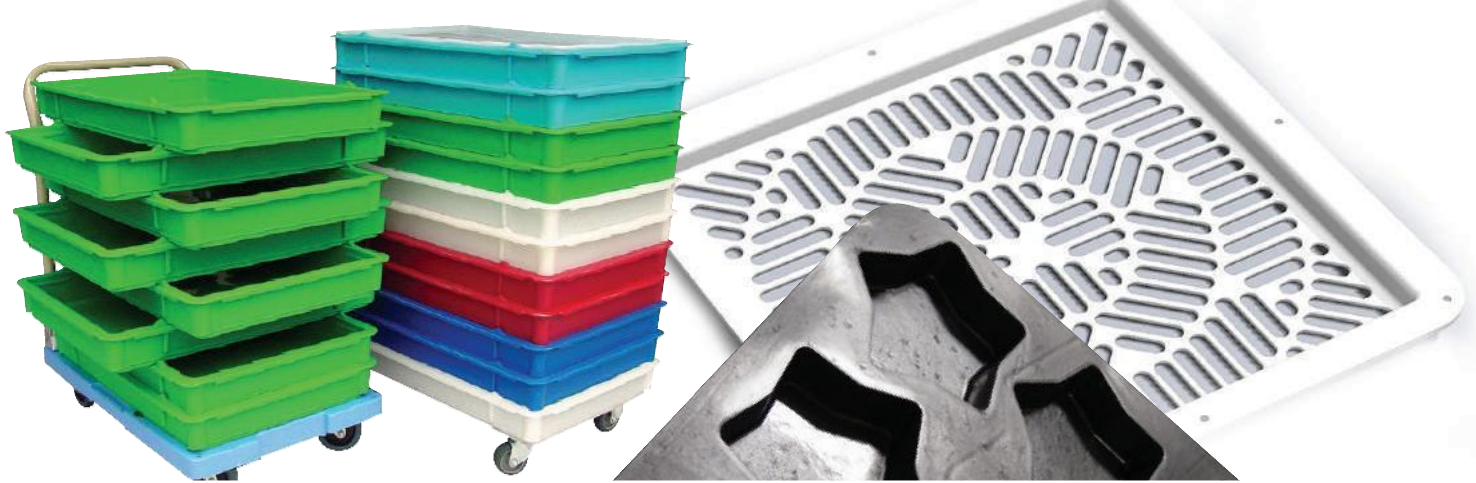

## WRH History

WRH Industries has developed, commercialized and innovated the plastics business for more than 60 years, creating processes, products and patents for commercial applications.

Our founder, Arthur Hartwell, was a plastics pioneer in historic applications such as moulding Titleist's first golf balls and Samsonite's clamshell luggage, and co-invented structural foam moulding as a new and now globally-recognized moulding technique. In 1972, Warren Hartwell established plastics as a next generation material for the pharmaceutical, confectionery and food processing industries.

## WRH Advantages

- Your manufacturing choice for environmentally-friendly direct food contact handling and packaging solutions.
- Our strength is your security, protecting your safety, quality, and productivity with patented USDA/FDA/NSF compliant extreme-temperature direct-food contact materials and designs.
- Four generations of unparalleled plastic engineering, design capabilities and material expertise.
- Our customer-focused culture offers cutting-edge innovations and collaborative engineering to meet your challenges.

## WRH Today

In addition to our core food processing, confectionery and pharmaceutical clientele, we have spent more than twenty years successfully serving the QSR, foodservice, meat, seafood, grocery and agricultural sectors with innovative and state-of-the-art solutions in handling, process, equipment and ecological packaging.

*We look forward to earning your business and exceeding your expectations.*



*Our Strength is Your Security.*

957 Airport Road, Fall River, MA 02720 USA  
 1-800-FDA-TRAY (1-800-332-8729)  
 1-508-674-2444 | solutions@wrh.net

For complete product information, visit [www.wrh.net](http://www.wrh.net)

**Our material handling, process and packaging solutions serve a variety of industries including, but not limited to:**

Food Processing | Meat | Candy | Pharmaceutical | Agriculture  
 Pizza | Bakery | Foodservice | Grocery | QSR | Industrial  
 Custom Solutions | Tunnel Washers | Green Packaging





# Agriculture

WRH Industries Ltd. is proud to offer a full line of products perfectly suited to the agriculture industry. From drying and dehydration trays, racks and dollies to boxes and trays for blast freezing and cook/chill applications to industrial washing machines, we can provide a complete solution for your business.

Our patented Teflon® and extreme temperature-tolerant thermoplastics combined with our unrivaled five-year breakage warranties demonstrate how our strength is your security.



***Our Strength is Your Security.***

957 Airport Road, Fall River, MA 02720 USA  
1-800-FDA-TRAY (1-800-332-8729)  
1-508-674-2444 | solutions@wrh.net

For complete product information, visit [www.wrh.net](http://www.wrh.net)

**Our material handling, process and packaging solutions serve a variety of industries including, but not limited to:**

Food Processing | Meat | Candy | Pharmaceutical | Agriculture  
Pizza | Bakery | Foodservice | Grocery | QSR | Industrial  
Custom Solutions | Tunnel Washers | Green Packaging





# Bakery and Pastry Arts

WRH Industries Ltd. is proud to offer a full line of products perfectly suited for the bakery industry. From dough handling systems of trays, boxes and racks to half and full-size sheet pans to non-stick pan liners and mats, we can provide a complete solution for your business.

Our patented Teflon® and extreme temperature-tolerant thermoplastics combined with our unrivaled five-year breakage warranties demonstrate how our strength is your security.

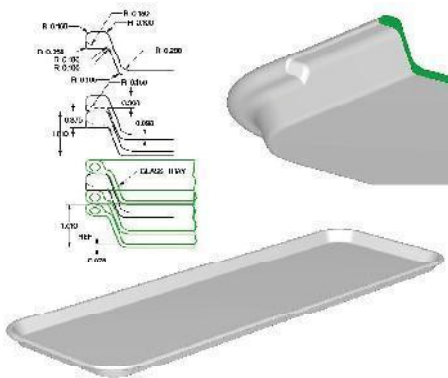

***Our Strength is Your Security.***

957 Airport Road, Fall River, MA 02720 USA  
1-800-FDA-TRAY (1-800-332-8729)  
1-508-674-2444 | solutions@wrh.net

For complete product information, visit [www.wrh.net](http://www.wrh.net)

**Our material handling, process and packaging solutions serve a variety of industries including, but not limited to:**

Food Processing | Meat | Candy | Pharmaceutical | Agriculture  
Pizza | Bakery | Foodservice | Grocery | QSR | Industrial  
Custom Solutions | Tunnel Washers | Green Packaging





# Candy / Pharmaceutical

WRH Industries Ltd. is proud to offer a full line of products perfectly suited to the candy-making and pharmaceutical industries. From chocolate and candy moulds to stock boxes to demoulding plaques to cooling and drying trays, we can provide a complete solution for your business.

Our patented Teflon® and extreme temperature-tolerant thermoplastics combined with our unrivaled five-year breakage warranties demonstrate how our strength is your security.



*Our Strength is Your Security.*

957 Airport Road, Fall River, MA 02720 USA  
1-800-FDA-TRAY (1-800-332-8729)  
1-508-674-2444 | solutions@wrh.net

For complete product information, visit [www.wrh.net](http://www.wrh.net)

**Our material handling, process and packaging solutions serve a variety of industries including, but not limited to:**

Food Processing | Meat | Candy | Pharmaceutical | Agriculture  
Pizza | Bakery | Foodservice | Grocery | QSR | Industrial  
Custom Solutions | Tunnel Washers | Green Packaging





# Custom Solutions

WRH Industries Ltd. can design and create applications exclusively tailored to your business or industry. We have nearly 60 years of experience in working with clients from large multi-national corporations to single-proprietor shops in creating and engineering custom solutions to meet their unique requirements. With our proprietary FDA-certified and virtually-indestructible materials, we can design and manufacture the right system to complement your business.

Our patented Teflon® and extreme temperature-tolerant thermoplastics combined with our unrivaled five-year breakage warranties demonstrate how our strength is your security.

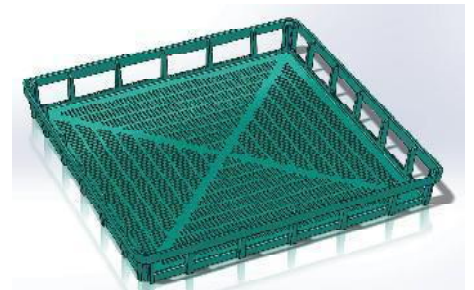
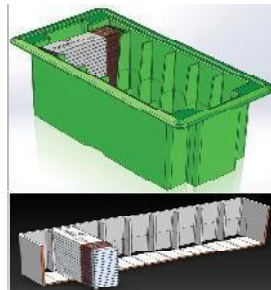
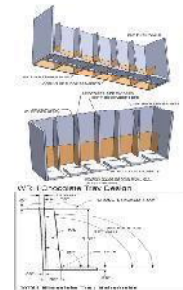
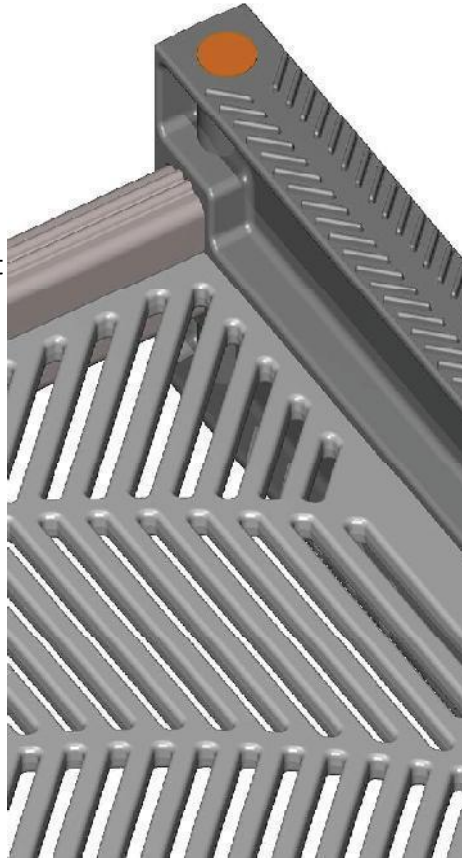

***Our Strength is Your Security.***

957 Airport Road, Fall River, MA 02720 USA  
1-800-FDA-TRAY (1-800-332-8729)  
1-508-674-2444 | solutions@wrh.net

For complete product information, visit [www.wrh.net](http://www.wrh.net)

**Our material handling, process and packaging solutions serve a variety of industries including, but not limited to:**

Food Processing | Meat | Candy | Pharmaceutical | Agriculture  
Pizza | Bakery | Foodservice | Grocery | QSR | Industrial  
Custom Solutions | Tunnel Washers | Green Packaging





# Foodservice

WRH Industries Ltd. is proud to offer a full line of products perfectly suited to the food processing industry. From trays and bins for commissary applications to sheet pans to freeze/transport trays, we can provide a complete solution for your business.

Our patented Teflon® and extreme temperature-tolerant thermoplastics combined with our unrivaled five-year breakage warranties demonstrate how our strength is your security.



***Our Strength is Your Security.***

957 Airport Road, Fall River, MA 02720 USA  
1-800-FDA-TRAY (1-800-332-8729)  
1-508-674-2444 | solutions@wrh.net

For complete product information, visit [www.wrh.net](http://www.wrh.net)

**Our material handling, process and packaging solutions serve a variety of industries including, but not limited to:**

Food Processing | Meat | Candy | Pharmaceutical | Agriculture  
Pizza | Bakery | Foodservice | Grocery | QSR | Industrial  
Custom Solutions | Tunnel Washers | Green Packaging





# Functional and Medical Edibles



WRH Industries Ltd. is proud to offer a full line of products perfectly suited to your edibles production applications. From chocolate, gummy, caramel, gums, toffees and hard candy moulds to stock boxes, demoulding plaques and cooling and drying trays, we can provide a complete solution for your functional and medicated business.

Our patented Teflon® and extreme temperature-tolerant thermoplastics combined with our unrivaled five-year breakage warranties demonstrate how our strength is your security.

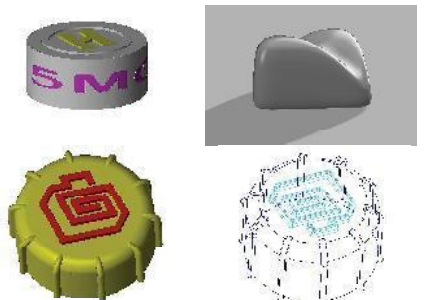
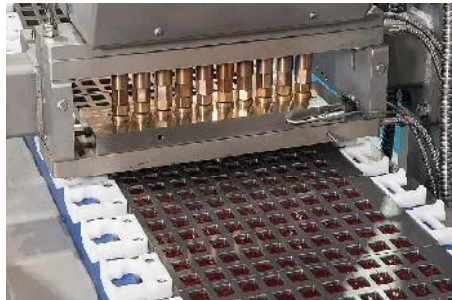
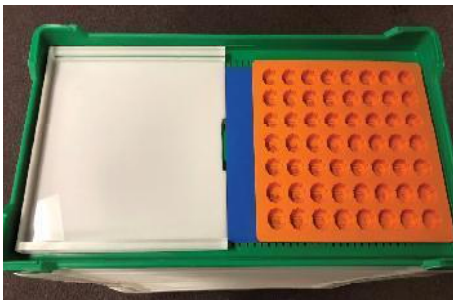
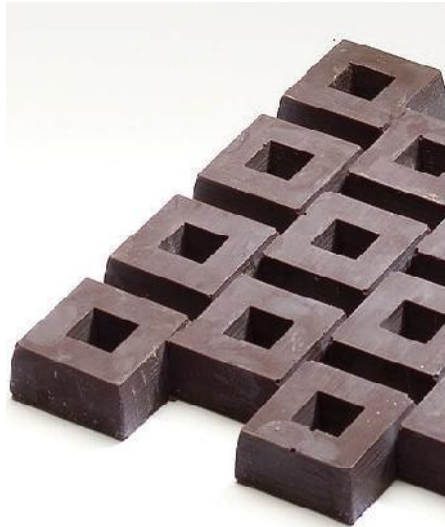

***Our Strength is Your Security.***

957 Airport Road, Fall River, MA 02720 USA  
1-800-FDA-TRAY (1-800-332-8729)  
1-508-674-2444 | solutions@wrh.net

For complete product information, visit [www.wrh.net](http://www.wrh.net)

**Our material handling, process and packaging solutions serve a variety of industries including, but not limited to:**

Food Processing | Meat | Candy | Pharmaceutical | Agriculture  
Pizza | Bakery | Foodservice | Grocery | QSR | Industrial  
Custom Solutions | Tunnel Washers | Green Packaging







# Green Packaging

WRH Industries Ltd. is proud to offer a full line of eco-friendly products perfectly suited to the needs of your industry. From eco-straws, cutlery and plates, carry-out containers to multi-use totes, hydro-degradable bags and reusable pan liners, we can provide a complete solution for your business.

Our environmental commitments include organic and eco-friendly materials to significantly reduce waste and disposal concerns caused by polystyrene foam and plastic food service items. Our compostable food packaging products are made from rapidly renewable crops like sugarcane, bamboo and wheat straw.

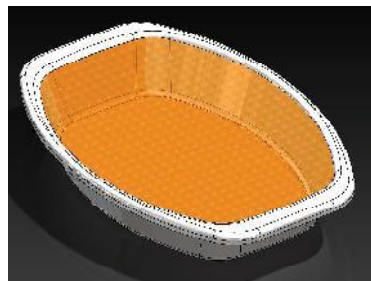

***Our Strength is Your Security.***

957 Airport Road, Fall River, MA 02720 USA  
1-800-FDA-TRAY (1-800-332-8729)  
1-508-674-2444 | solutions@wrh.net

For complete product information, visit [www.wrh.net](http://www.wrh.net)

**Our material handling, process and packaging solutions serve a variety of industries including, but not limited to:**

Food Processing | Meat | Candy | Pharmaceutical | Agriculture  
Pizza | Bakery | Foodservice | Grocery | QSR | Industrial  
Custom Solutions | Tunnel Washers | Green Packaging



**COMPOSTABLE**  
IN INDUSTRIAL FACILITIES  
Check locally, as these do not exist in many communities. Not suitable for backyard composting.





# Grocery

WRH Industries Ltd. is proud to offer a full line of products perfectly suited for the grocery/supermarket industry. From cook/chill and blast freezing bins and trays to sheet pans and non-stick pan liners to dollies and carts, we can provide a complete solution for your business.

Our patented Teflon® and extreme temperature-tolerant thermoplastics combined with our unrivaled five-year breakage warranties demonstrate how our strength is your security.



***Our Strength is Your Security.***

957 Airport Road, Fall River, MA 02720 USA  
1-800-FDA-TRAY (1-800-332-8729)  
1-508-674-2444 | solutions@wrh.net

For complete product information, visit [www.wrh.net](http://www.wrh.net)

**Our material handling, process and packaging solutions serve a variety of industries including, but not limited to:**

Food Processing | Meat | Candy | Pharmaceutical | Agriculture  
Pizza | Bakery | Foodservice | Grocery | QSR | Industrial  
Custom Solutions | Tunnel Washers | Green Packaging





# Industrial Applications

WRH Industries Ltd. is proud to offer a full line of products perfectly suited for industrial applications. From dust-tight stackable trays and boxes to drying and dehydration systems with racks and dollies to industrial washing machines, we can provide a complete solution for your business.

Our patented Teflon® and extreme temperature-tolerant thermoplastics combined with our unrivaled five-year breakage warranties demonstrate how our strength is your security.

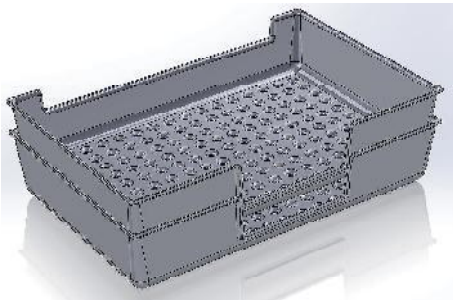
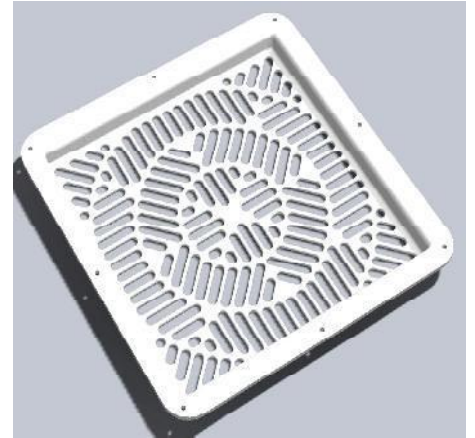

***Our Strength is Your Security.***

957 Airport Road, Fall River, MA 02720 USA  
1-800-FDA-TRAY (1-800-332-8729)  
1-508-674-2444 | solutions@wrh.net

For complete product information, visit [www.wrh.net](http://www.wrh.net)

**Our material handling, process and packaging solutions serve a variety of industries including, but not limited to:**

Food Processing | Meat | Candy | Pharmaceutical | Agriculture  
Pizza | Bakery | Foodservice | Grocery | QSR | Industrial  
Custom Solutions | Tunnel Washers | Green Packaging





# Meat / Fish / Poultry

WRH Industries Ltd. is proud to offer a full line of products perfectly suited to the meat / fish / poultry processing industries. From precook systems to blast freezing trays / boxes to sheet pans and boning trays, we can provide a complete solution for your business.

Our patented Teflon® and extreme temperature-tolerant thermoplastics combined with our unrivaled five-year breakage warranties demonstrate how our strength is your security.

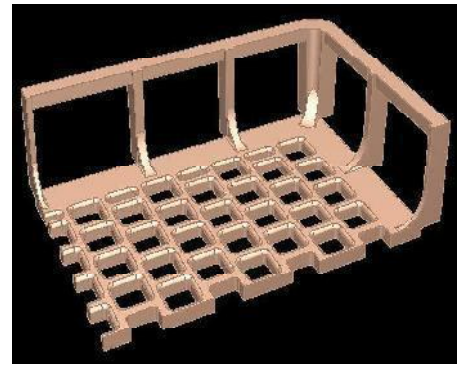

***Our Strength is Your Security.***

957 Airport Road, Fall River, MA 02720 USA  
1-800-FDA-TRAY (1-800-332-8729)  
1-508-674-2444 | solutions@wrh.net

For complete product information, visit [www.wrh.net](http://www.wrh.net)

**Our material handling, process and packaging solutions serve a variety of industries including, but not limited to:**

Food Processing | Meat | Candy | Pharmaceutical | Agriculture  
Pizza | Bakery | Foodservice | Grocery | QSR | Industrial  
Custom Solutions | Tunnel Washers | Green Packaging





# Pizza Restaurant / Commissary

WRH Industries Ltd. is proud to offer a full line of products perfectly suited for the pizza industry. From dough handling systems including trays, boxes, racks and scrapers to non-stick pan liners to industrial washing machines, we can provide a complete solution for your business.

Our patented Teflon® and extreme temperature-tolerant thermoplastics combined with our unrivaled five-year breakage warranties demonstrate how our strength is your security.



***Our Strength is Your Security.***

957 Airport Road, Fall River, MA 02720 USA  
1-800-FDA-TRAY (1-800-332-8729)  
1-508-674-2444 | solutions@wrh.net

For complete product information, visit [www.wrh.net](http://www.wrh.net)

**Our material handling, process and packaging solutions serve a variety of industries including, but not limited to:**

Food Processing | Meat | Candy | Pharmaceutical | Agriculture  
Pizza | Bakery | Foodservice | Grocery | QSR | Industrial  
Custom Solutions | Tunnel Washers | Green Packaging





# QSR

WRH Industries Ltd. is proud to offer a full line of products perfectly suited for the restaurant / QSR industry. From racks and dollies, to display and transport trays to reusable non-stick pan liners to cold brew systems, we offer a complete solution for your business.

Our patented Teflon® and extreme temperature-tolerant thermoplastics combined with our unrivaled five-year breakage warranties demonstrate how our strength is your security.

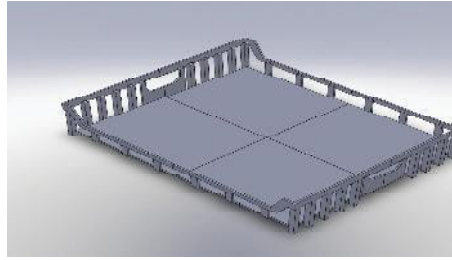

***Our Strength is Your Security.***

957 Airport Road, Fall River, MA 02720 USA  
1-800-FDA-TRAY (1-800-332-8729)  
1-508-674-2444 | solutions@wrh.net

For complete product information, visit [www.wrh.net](http://www.wrh.net)

**Our material handling, process and packaging solutions serve a variety of industries including, but not limited to:**

Food Processing | Meat | Candy | Pharmaceutical | Agriculture  
Pizza | Bakery | Foodservice | Grocery | QSR | Industrial  
Custom Solutions | Tunnel Washers | Green Packaging





# Tunnel Washing Systems

WRH Industries Ltd. is proud to offer a full line of tunnel washing systems perfectly suited for all applications and industries. From standard and custom tunnel washing systems to blow-off units to dryers, we can provide a complete solution for your business that will complement your material handling requirements.

Our patented Teflon® and extreme temperature-tolerant thermoplastics combined with our unrivaled five-year breakage warranties demonstrate how our strength is your security.



***Our Strength is Your Security.***

957 Airport Road, Fall River, MA 02720 USA  
1-800-FDA-TRAY (1-800-332-8729)  
1-508-674-2444 | solutions@wrh.net

For complete product information, visit [www.wrh.net](http://www.wrh.net)

**Our material handling, process and packaging solutions serve a variety of industries including, but not limited to:**

Food Processing | Meat | Candy | Pharmaceutical | Agriculture  
Pizza | Bakery | Foodservice | Grocery | QSR | Industrial  
Custom Solutions | Tunnel Washers | Green Packaging



# Exceeding customer expectations for more than 60 years..



***Our Strength is Your Security.***

957 Airport Road, Fall River, MA 02720 USA  
 1-800-FDA-TRAY (1-800-332-8729)  
 1-508-674-2444 | solutions@wrh.net

For complete product information, visit [www.wrh.net](http://www.wrh.net)

**Our material handling, process and packaging solutions serve a variety of industries including, but not limited to:**

Food Processing | Meat | Candy | Pharmaceutical | Agriculture  
 Pizza | Bakery | Foodservice | Grocery | QSR | Industrial  
 Custom Solutions | Tunnel Washers | Green Packaging

